

CAD FILE:

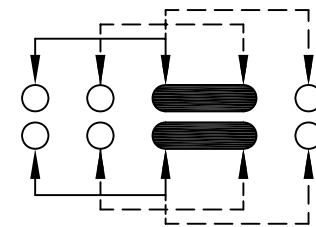

SCHMATIC(SHORTING)

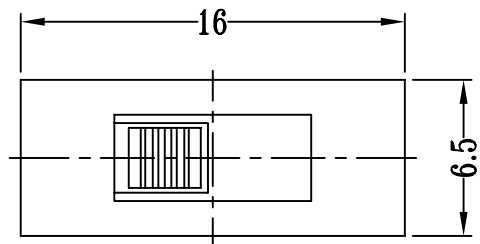
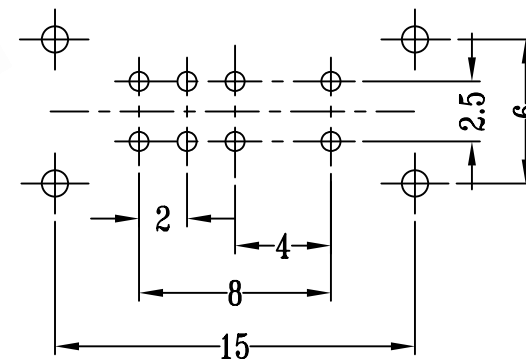
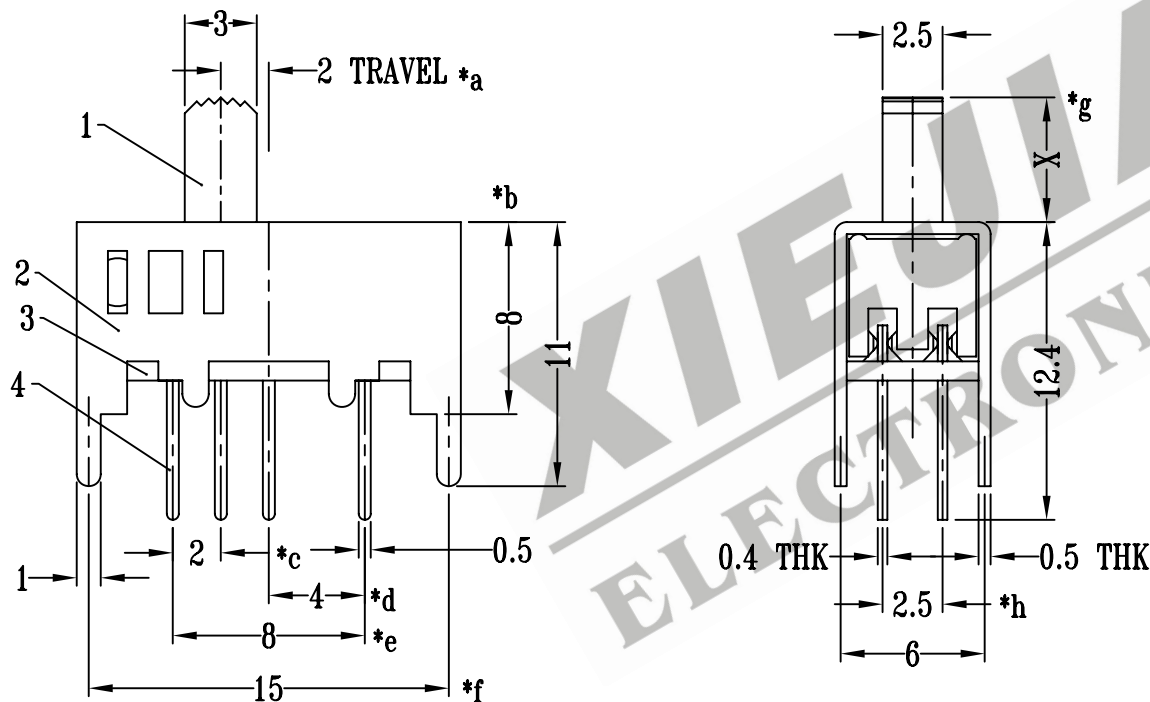

P.C.B LAYOUT

注:带"*"表示关键尺寸(8个)

8					TOLERANCE	SHENZHEN XIEJIA ELECTRONICS CO.,LTD.				
7	STEEL BALL	STEEL	1	NATURAL	UNLESS SPECIFIED					
6	SPRING	STEEL WIRE	1	TEMPER	WITHIN: 1.5±0.1mm	ISSUE	DATE	DESCRIPTIONS OF REVISION		APPD.
5	CONTACT CLIP	PBS STRIP	2	Ag PLATED	OVER : 1.5±0.2mm					
4	TERMINAL	BRASS STRIP	8	Ag PLATED OVER Ni PLATED	TITLE : VERTICAL SLIDE SWITCH	UNIT : mm		DRWG NO.: XJ-DR-SS23D03-00		
3	BASE	PHENOLIC RESIN	1	NATURAL	MODEL: SS-23D03	SCALE: 3:1		DWN.	ZHOUYU	2002-12-5
2	FRAME	STEEL STRIP	1	Ni PLATED	ALL MATERIALS MUST BE COMPLIANT TO ROHS			CHK'D	FANGYING	2002-12-5
1	KNOB	POM	1	BLACK				APPD.	KANGXINAN	2002-12-5
NO.	PARTS	MATERIALS	Q'TY	FINISH						